

## INSTALLATION MANUAL

### Content

1. General information.....	1
2. Safety precautions.....	1
3. Storage and unpacking .....	1
4. Product identification.....	2
5. Mechanical installation .....	2
5.1 Climate condition .....	2
5.2 Site selection .....	2
5.3 Module tilt angle.....	2
5.4 Installation methods.....	3,4
6. Electrical installation.....	5
6.1 Module wiring .....	5
6.2 Grounding.....	5
7. Maintenance.....	6
8. Disclaimer of liability.....	6

# German Solar

---

## 1. General information

This manual contains information regarding the installation and safe handling of GermanSolar photovoltaic modules. Installers should read this manual carefully and follow the instructions strictly prior to installing the modules. Failure to follow these instructions may result in death, bodily injury or damage to property.

The installation of modules requires specialized skills and should only be performed by qualified, licensed professionals. If you have any questions about installation, please contact us for further information.

## 2. Safety precautions

- ◆ GermanSolar modules have passed all required safety tests according to the IEC 61730 and are rated with Application Class A, and within this application class modules are considered to meet the requirements for Safety Class II.
- ◆ All installations must be performed in compliance with all local and national applicable standards, codes and regulations.
- ◆ Installers should assume all risks of injury that might occur during installation, including, but not limited to, the risk of electric shock.
- ◆ Do not use mirrors or other magnifiers to artificially concentrate sunlight on the modules.
- ◆ Do not attempt to disassemble the modules or remove any components from the modules.
- ◆ Do not install the module in the rain, snow or in windy conditions.
- ◆ Use electrical insulated tools and appropriate protective equipment to reduce risk of electric shock.
- ◆ Cover the module with an opaque material during installation to keep electricity from being generated.
- ◆ Do not disconnect under load.

## 3. Storage and unpacking

- ◆ Store modules in a dry and ventilated room.
- ◆ Unpack module pallets with care and follow the unpacking steps. Be careful when unpacking, transporting, and storing the modules.
- ◆ Do not lift the module by grasping the module's junction box or electrical leads.
- ◆ Do not place modules on top of each other.
- ◆ Do not stand or step on the module.
- ◆ Do not drop the module or allow objects to fall on the module.
- ◆ Do not leave the module unsupported or unsecured.
- ◆ Keep all electrical contacts clean and dry.

## 4. Product identification

Each GermanSolar module has two identical barcodes with 15 digits for its unique identification (one is in the laminate, and the second is on the back-sheet). A nameplate is affixed on the backside of the module.

# German Solar

---

This nameplate describes main characteristics of the module, which include the product type, maximum power, open circuit voltage, short circuit current, maximum power voltage, maximum power current, all as measured under standard test conditions; maximum system voltage, weight, dimensions etc..

Do not remove any labels from the module. If the label was moved out, the module will void the warranty.

## 5. Mechanical installation

### 5.1 Climate condition

GermanSolar modules should be installed in the following conditions:

Ambient temperature:  $-20^{\circ}\text{C}$  to  $+40^{\circ}\text{C}$

Operating temperature:  $-40^{\circ}\text{C}$  to  $+85^{\circ}\text{C}$

Storage temperature:  $-40^{\circ}\text{C}$  to  $+40^{\circ}\text{C}$

Humidity: below 85RH%

Wind load: below 2400Pa

Snow load: below 5400Pa

### 5.2 Site selection

GermanSolar modules should be installed in a location where they will receive maximum sunlight throughout the year. In the northern hemisphere, the module should typically face south, and in the southern hemisphere, the modules should typically face north.

When choosing a site, avoid trees, buildings or obstructions, which could cast shadows on the modules especially during the winter months when the arc of the sun is lowest over the horizon. Shading causes loss of output, even though bypass diodes have been fitted in the junction box of the module to minimize any such loss.

Do not install the module near naked flame or flammable materials.

Do not install the module in a location where it would be immersed in water or continually exposed to water from a sprinkler or fountain etc.

### 5.3 Module tilt angle

Modules connected in series should be installed at same orientation and angle. Different orientation or angle may cause loss of output power due to difference of amount of sunlight exposed to the module.

Modules produce the most power when they are pointed directly at the sun.

For installations where the modules are attached to a permanent structure, the modules should be tilted for optimum winter performance. As a rule, if the system power production is adequate in winter, it will be satisfactory during the rest of the year. Optimal tilting of the module is roughly the same as the latitude of installation location.

### 5.4 Installation methods

The modules can be installed on the frame using screw mounting and clamp mounting methods (as shown in Fig.1).

# German Solar

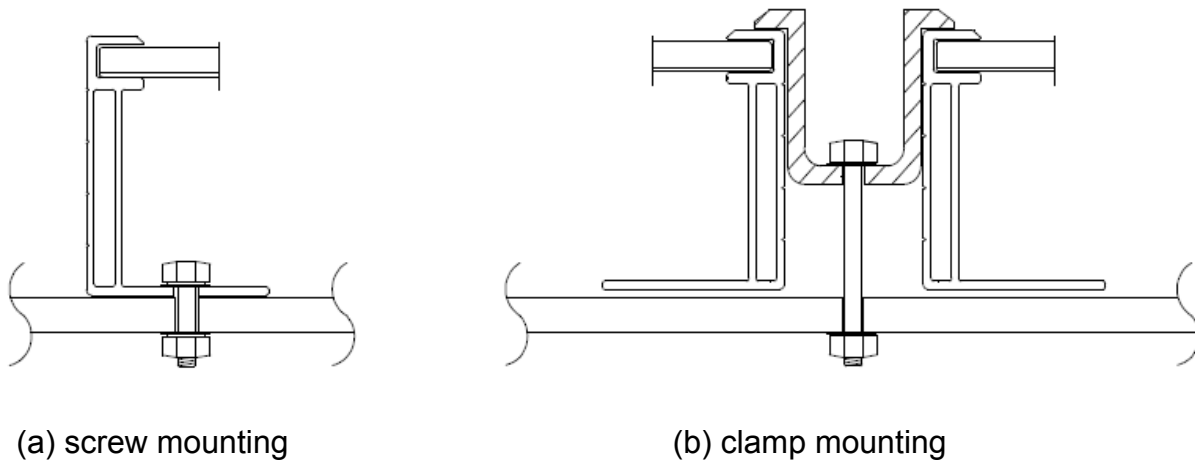

Fig.1 The module installed with (a) screw mounting, (b) clamp mounting

## (a) Screw mounting

The frame of each module has eight mounting holes used to secure the modules to the support structure. If the wind or snow loads is less than 2400Pa, you can use the four symmetry holes close to the inner side on module frame(as shown in Fig.2). If the wind or snow load exceeds 2400Pa, you must use all the eight mounting holes. The module frame must be attached to a mounting rail using M8 corrosion-proof screws together with spring washers and flat washers in eight symmetrical locations on the module.

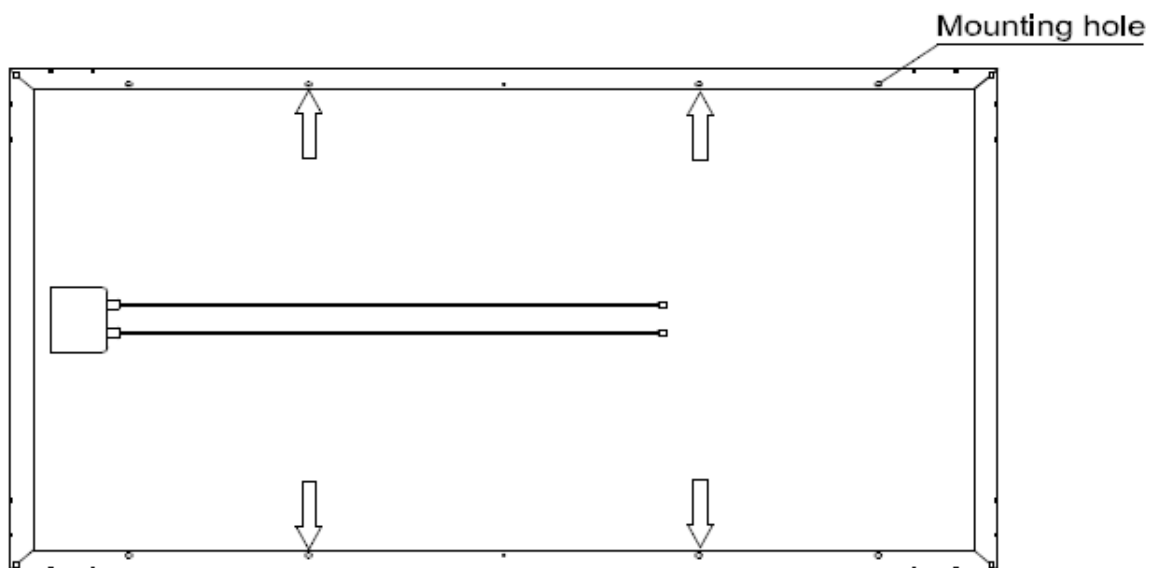

Fig.2 The module installed on long frames with screw mounting method

## (b) Clamp mounting

- ◆ The modules can be installed in both landscape(clamping on the short frame) and portrait (clamping on the long frame) modes by clamp mounting.

# German Solar

---

- ◆ The module clamps should not come into contact with the front glass and must not deform the frame.
- ◆ Be sure to avoid shadowing effects from the module clamps.
- ◆ The module frame is not to be modified under any circumstances.
- ◆ When choosing this type of clamp mounting method, please be sure to use at least four clamps on each module, two clamps should be attached on each frame of the module. Depending on the local wind and snow loads, if the pressure load exceeds 2400Pa, additional clamps or support would be required to ensure the module can bear the load.

For clamping mounting on the long or short frame of the module, please refer to Fig.3 and Fig.4.

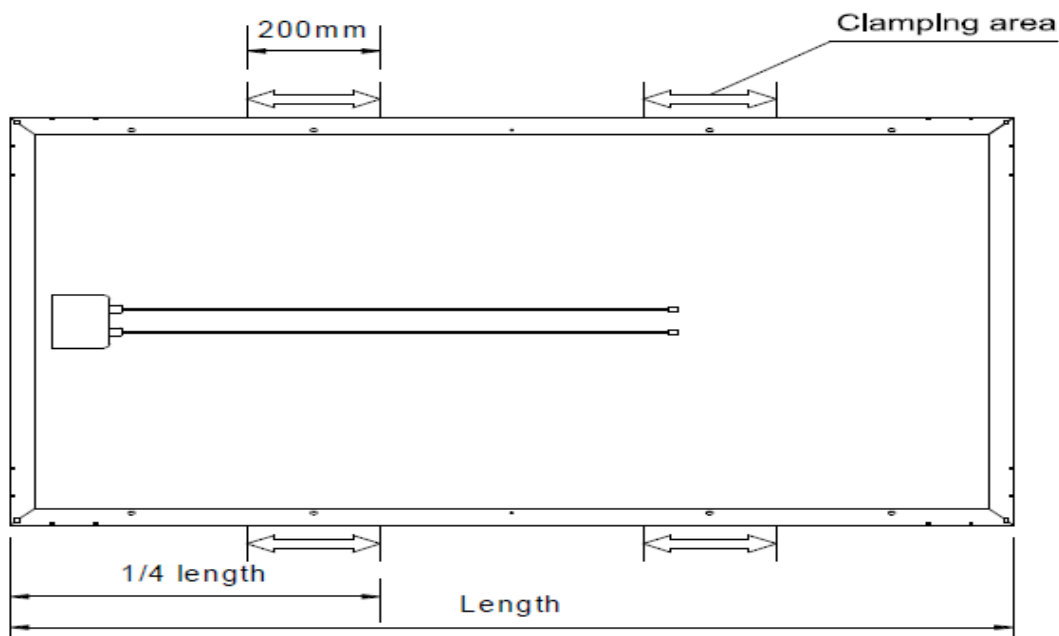

Fig.3 The module installed on long frames with clamp mounting method

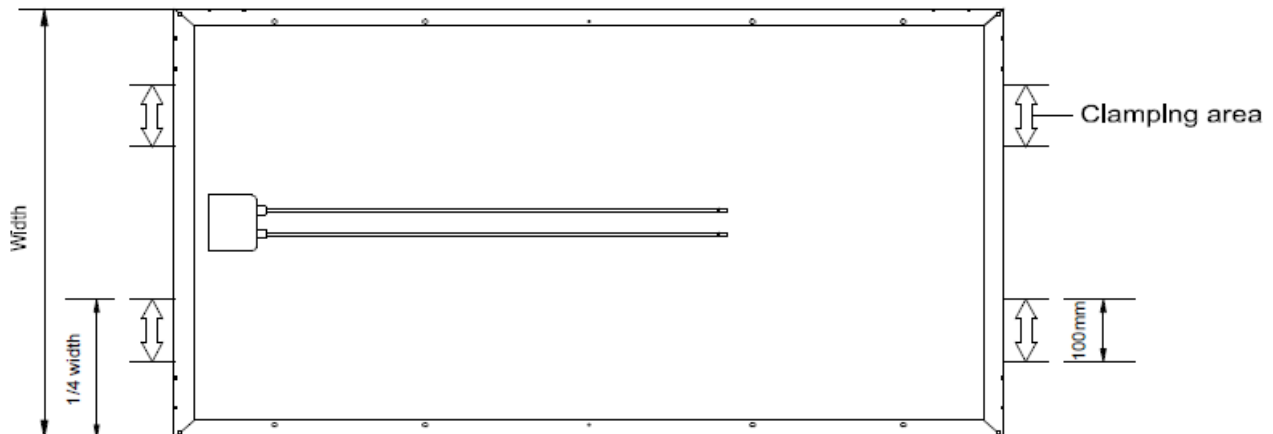

Fig.4 The module installed on short frames with clamp mounting method

## 6. Electrical installation

### 6.1 Module wiring

Modules are supplied with cables and connectors to be used for system electrical connections. It is not recommended to use modules with different configurations and electrical characteristics in the same system.

Modules can be connected in series to obtain a high operating voltage. The system voltage is equal to the sum of the voltage of each module. Modules can also be connected in parallel to obtain a high operating currents. The system current is equal to the sum of the current of each string of modules. The maximum number of series connected modules depends on system design, the type of inverter used and environmental conditions. It should be noted that modules must not be connected together to create a voltage higher than the permitted system voltage. There is no limitation on the number of modules that can be connected in parallel, the number of modules is determined by system design parameters such as current or power output.

### 6.2 Grounding

#### Additional Third-party Grounding Devices

GermanSolar PV modules can be grounded using third party grounding devices - WEEB lugs of Wiley Electronics LLC and others - as long as they are certified for grounding PV modules and the devices are installed according to the manufacturer's specified instructions.

Grounding modules is necessary to reduce or eliminate shock and fire hazards. All module frames and mounting racks must be properly grounded in accordance with local and national electrical codes. Proper grounding is achieved by connecting the module frames and mounting racks continuously using a suitable grounding conductor. The grounding conductor or strap may be copper, copper alloy, or other material acceptable for use as an electrical conductor.

## 7. Maintenance

The following maintenance measures are recommended to ensure optimum performance of the modules:

- ◆ Under most weather conditions, normal rainfall is sufficient to keep the glass surface of modules clean. Clean the glass surface of the module as necessary.
- ◆ Always use clean water and a soft sponge or cloth for cleaning.
- ◆ If snow accumulates on top of the modules, remove the excess snow gently from the surface of the modules using a brush or broom.
- ◆ Check the electrical and mechanical connections periodically to make sure that all connections are tight, secure, intact and free of corrosion.
- ◆ Do not try to change the components of module (Junction box, bypass diode and connector).
- ◆ If any problem arises, consult a professional for suggestions.

## 8. Disclaimer of liability

Because the use of this manual and the conditions or methods of installation, operation, use and maintenance of the product are beyond GermanSolar's control, GermanSolar does not accept responsibility and expressly disclaims liability for loss, damage, or expense arising out of or in any way connected with such installation, operation, use or maintenance.

No responsibility is assumed by GermanSolar for any infringement of patents or other rights of third parties, which may result from use of the product. No license is granted by implication or otherwise under any patent or patent rights.

The information included in this manual is based on GermanSolar's knowledge and experience and is believed to be reliable; but such information including product specification (without limitations) and suggestions do not constitute a warranty, expresses or implied. GermanSolar reserves the right to change the manual.

### Germany

GermanSolar AG.  
Franz-Lehner-Strasse 3  
D-85716 Unterschleißheim  
Germany  
Tel: +49 (0) 89 3706865-0  
Fax: +49 (0) 89 3706865-10